

MOSCA®

STRAPPING SYSTEMS

AUTOMATIC PALLET STRAPPING MACHINE

Also available with
SONIX sealing



KZV 111

MOSCA pallet strapping machine
to secure goods for transport.

KZV 111 (BASIC MODEL)

MOSCA strapping machines are series-produced based on a modular principle. Sturdy design. Program-controlled integration into conveyor lines. Automatic vertical strapping. Robust single-column steel construction. Fully electrically-driven. Strap dispenser KA 400 for synthetic strapping tapes. With neutral-weight strap take-off and strap accumulator. Particularly suitable for automatic strapping of palletized packages. Top-mounted sealing head.

DIFFERENT MODELS

KZV 111, BASIC MODEL

- Top-mounted sealing head
- One KSR- sealing head and one vertical strap guide
- Movable strap lance for strapping palletized goods
- 2-column construction up to 2200 mm width

KOV 111, SPECIAL VERSION

- Like basic model KZV 111
- With additional closed strap track for strapping un-palletized goods (e.g. corrugated cardboard boxes...)

KVV 111, SPECIAL VERSION

- Like basic model KZV 111
- Bottom arch with automatically controlled strap lance or underfeed channel. Particularly suitable for strapping frequently changing package types with or without pallets.

K_V 121, SPECIAL VERSION

- Like variants KZV 111, KOV 111 and KVV 111
- Second sealing head with second strap guide, increased strapping performance through simultaneous parallel strapping with two sealing heads

OPTIONS

- Automatic height adjustment of pressure plate to bundle height
- Floating head
- Contact gibs
- Flap opener with package height scanning
- Conveying system (roller conveyor)
- **SONIX** ultrasonic sealing system

TECHNICAL DATA

CAPACITY:

Up to 60 Pallets/h; vertically double-strapped (with package height spread ± 200 mm)

ELECTRICAL POWER:

Operating Voltage: 400 V, 50 Hz,
3 PH / N / PE,
Control Voltage: 24 V DC
Total Connection: 4 kVA

STRAPPING:

Strap Types: Standard machine grade
PP or PET strap
Strap Sizes: Width: 9.5 - 16.0 mm
Break Strength: 2,200 - 7,500 N
Strap Tension: 250 - 2,500 N
infinitely adjustable
Strap Feed: 4.2 m/sec.

SEALING HEAD:

MOSCA friction-weld sealing head

WEIGHT:

1,200 kg

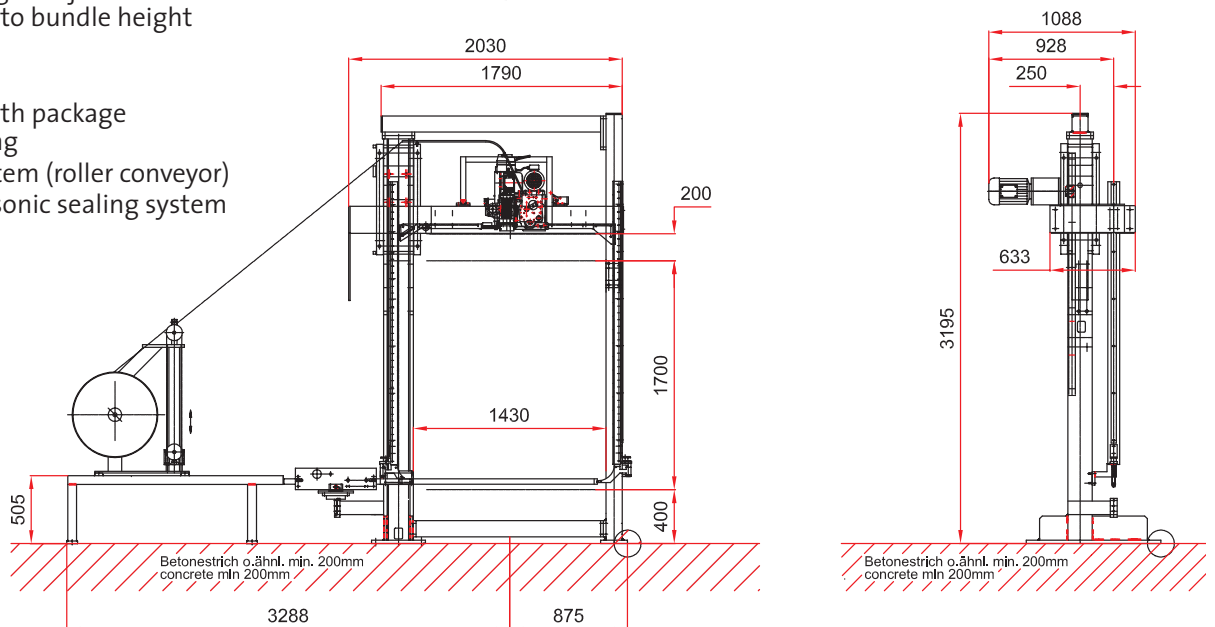

Gerd-Mosca-Straße 1
D-69429 Waldbrunn/Strümpfelbrunn
Tel.: +49 (0)6274/932-0
Fax: +49 (0)6274/932-400 118
Tel. After Sales: +49 (0)6274 / 932-100
Internet: <http://www.mosca-ag.com>
E-Mail: info@mosca-ag.com

MASCHINENFABRIK GERD MOSCA AG



11 / 09 Subject to Alterations

MOSCA AG stands for a worldwide, professional consulting, highest machine quality, optimal strapping material and a global, integrated service concept.